



THE NEW CHALLENGES OF O&M RELATED TO URBAN AND TOURISM ROPEWAYS

Mr Michaël FAUCHÉ,
Services Director





6 years ago :

NY (Aerial Tramway)

CAIRO (APM)



CEA (Horizontal Funicular)

Passengers and Customer satisfied, KPI reached

Renewal of Trust for more than 5 new years



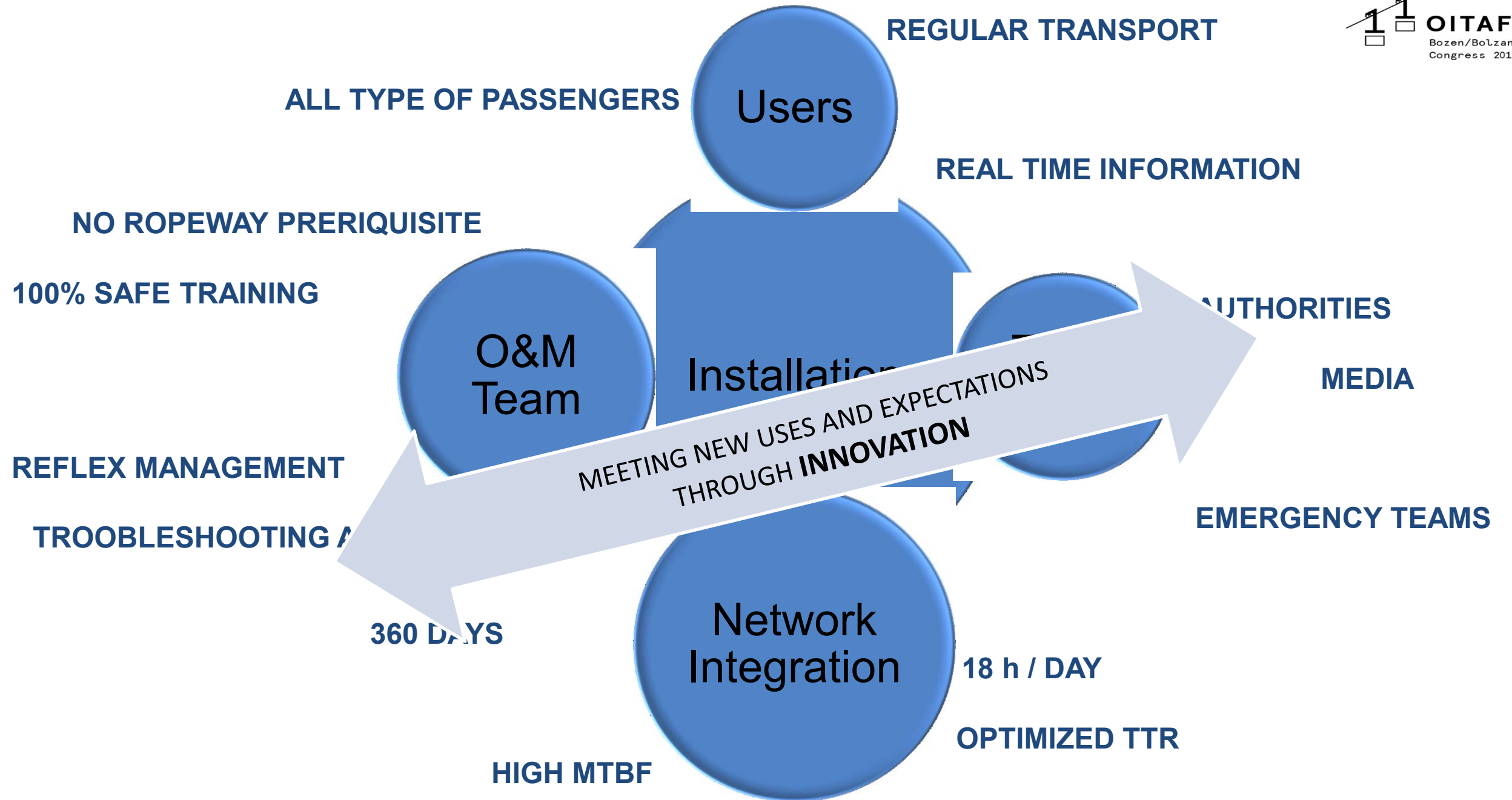





LRU
APPROACH

REDUNDANCY



DEGRADED
MODE:
designed for bad
weather
condition

INTEGRATED
TROUBLE
SHOOTING



UPILOT

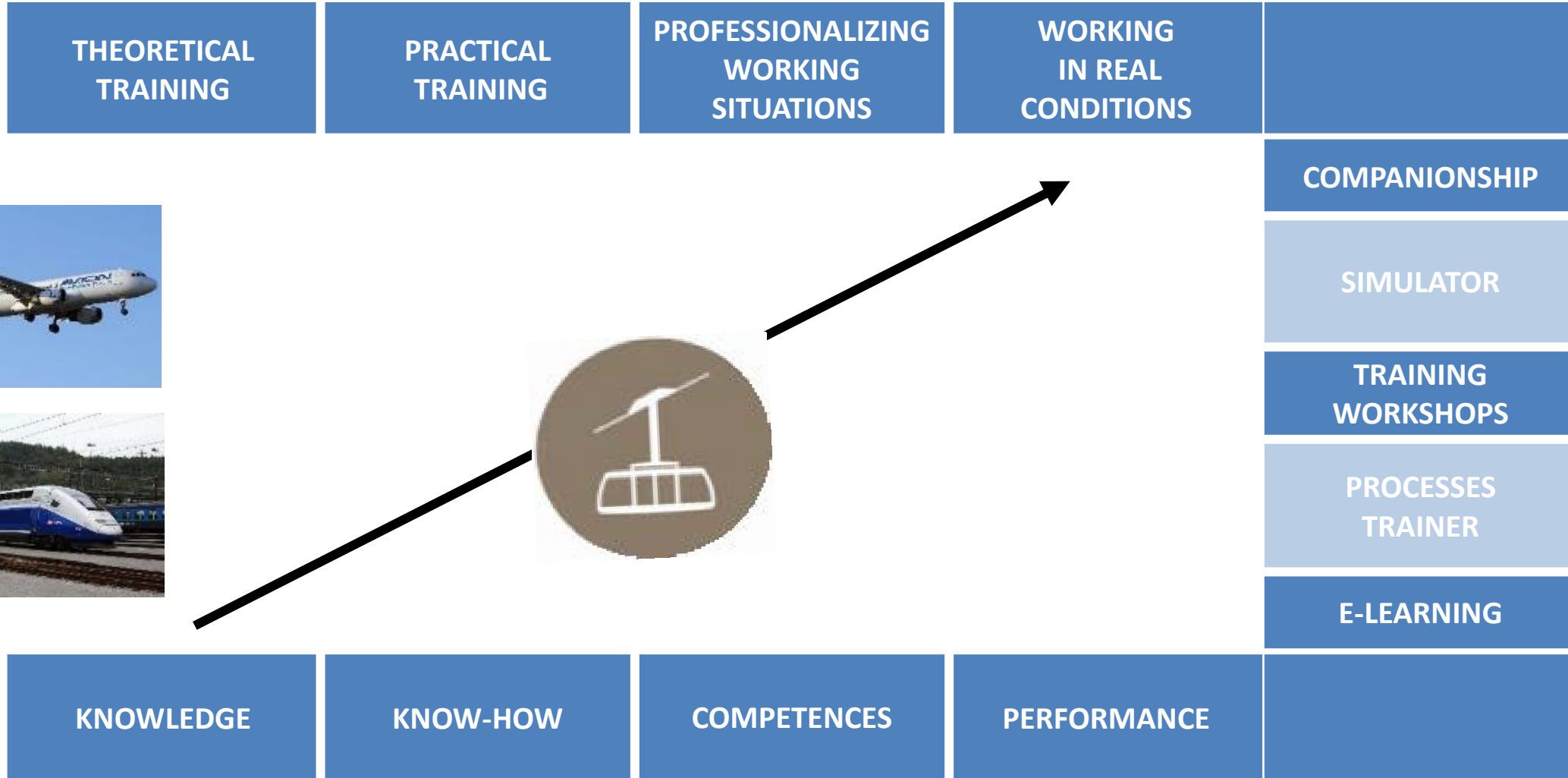
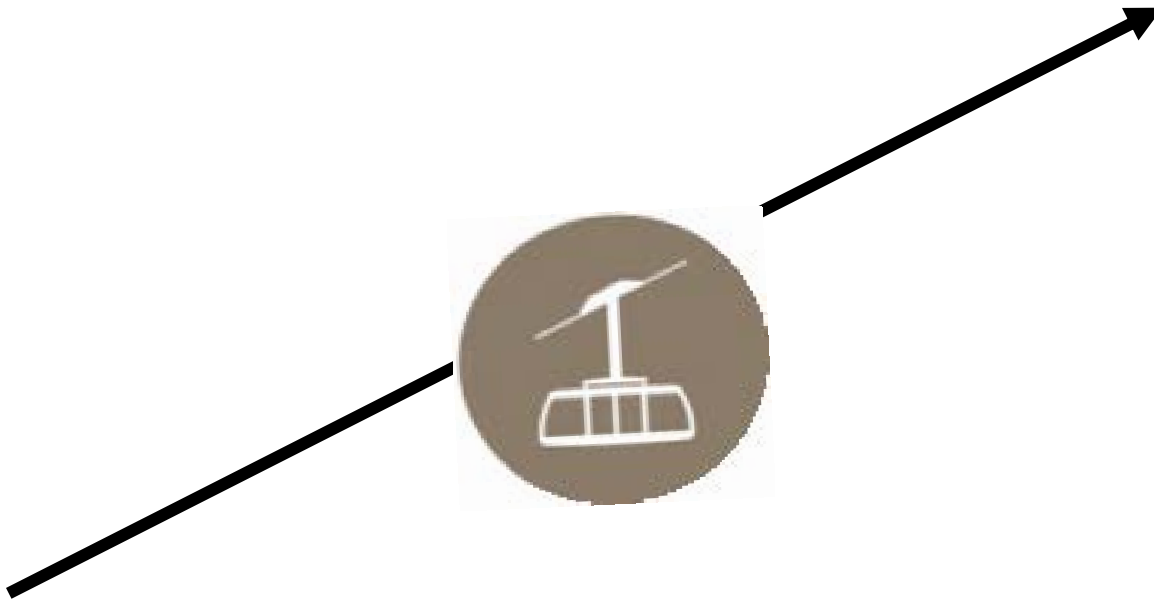



Menu Out X

Fonctionnement

Les deux moteurs de secours sont alimentés par de l'électricité.

Ils sont pilotés depuis le poste de conduite.



Motorisation de secours



E-LEARNING PLATFORM
PROCESSES TRAINER
SIMULATOR OF ROPEWAY SYSTEM



COURSES COMPLETION
DYNAMIC DELIVERY
DYNAMIC ASSESSMENT





Dedicated maintenance approach and maintenance planning,

Optimized tools for Hidden time operation,

Full traceability of Operation and Maintenance

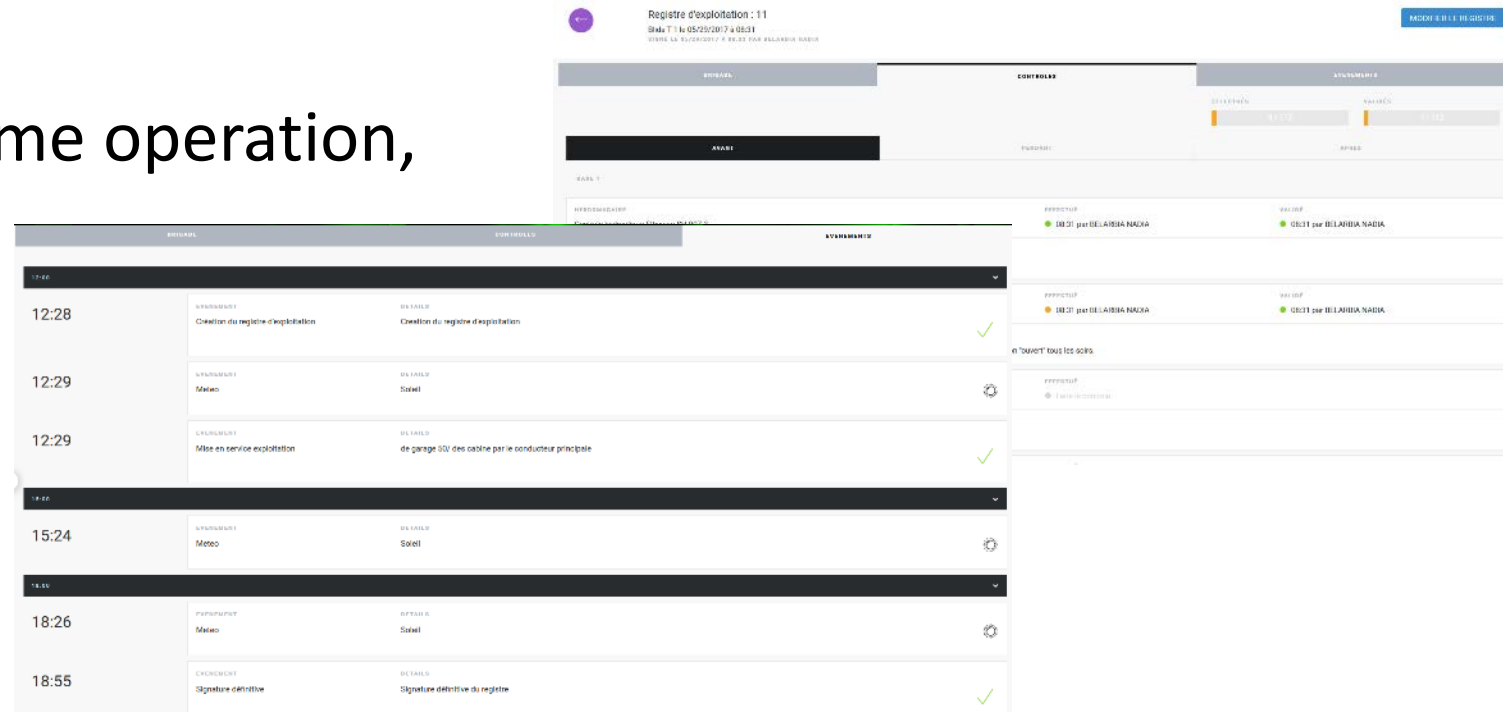

HEURE	SYSTEME	DE FAULT	STATUT
12:28	Creation du registre d'exploitation	Creation du registre d'exploitation	✓
12:29	Meteo	Soleil	⚙️
12:29	Mise en service exploitation	de garage 00/ des cabine par le conducteur principale	✓
15:24	Meteo	Soleil	⚙️
18:26	Meteo	Soleil	⚙️
18:55	Signature definitive	Signature definitive du registre	✓

OPERATEUR	VALVEUR
00 01 par DE LA BINA NADIA	0001 par BELLAHIA NADIA
00 02 par DE LA BINA NADIA	0002 par BELLAHIA NADIA

O&M Methodology Easy access to relevant documentation



Presentation of the hydraulic cylinder double-acting

Prior information Before using the equipment or working on it, it is essential to consult module B "Important information". For any information concerning the production of this manual or its summary, see sheet A300 or A301.

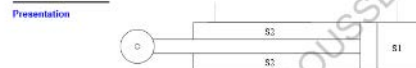

The hydraulic cylinder double-acting works using two chambers, a pressure chamber (S1) and a back-pressure chamber (S2).

Function The hydraulic cylinder is used for tensioning the rope, which it does by moving the tensioning carriage and the rollers that is attached to it. The advancement of the hydraulic cylinder is controlled by a hydraulic tension control unit. The hydraulic tension control unit is covered in another manual.

Functional sequence description If the pressure in the pressure chamber (S1) is raised, the piston rod is pushed out. The back-pressure chamber is emptied. If the back-pressure chamber (S2) is pressurised, the piston rod is pushed inwards. The pressure chamber is emptied. Blocking the flow out of either chamber prevents the piston rod from moving.

Hydraulic cylinder double-acting - Equipment presentation - a10_T2D/105_en

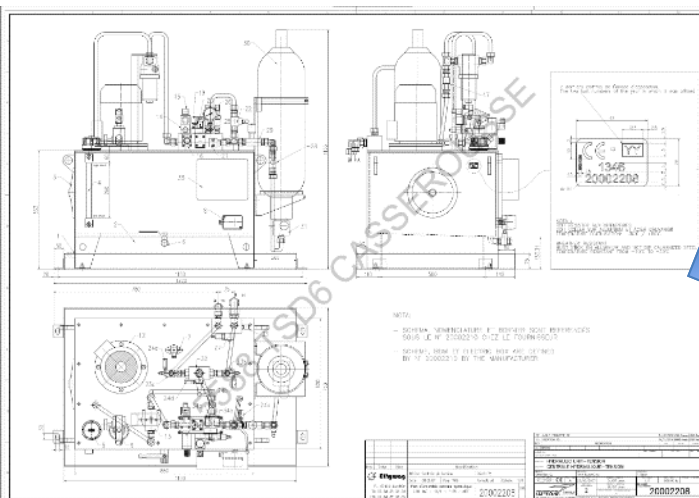
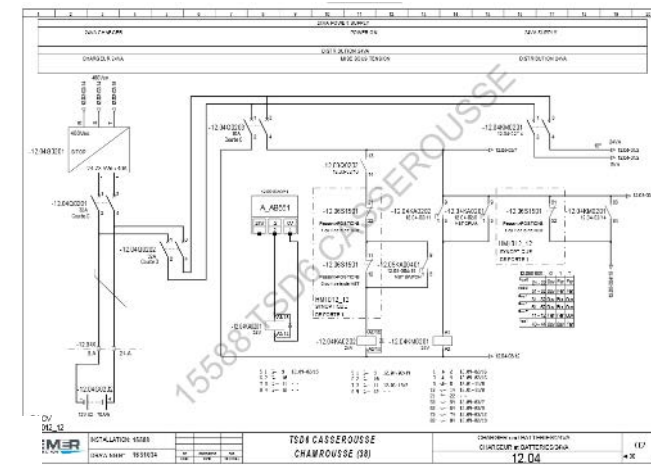
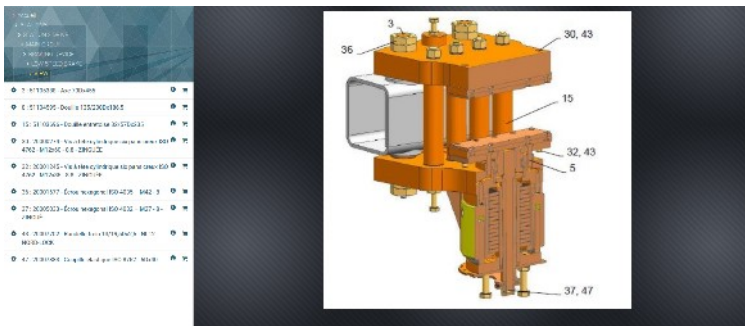



As other means of transportation...

- ✓ Remote monitoring and assistance,
- ✓ Real time analysis and troubleshooting,
- ✓ From Preventive to Predictive maintenance through a deep knowledge
- ✓ Infotainment to passengers.

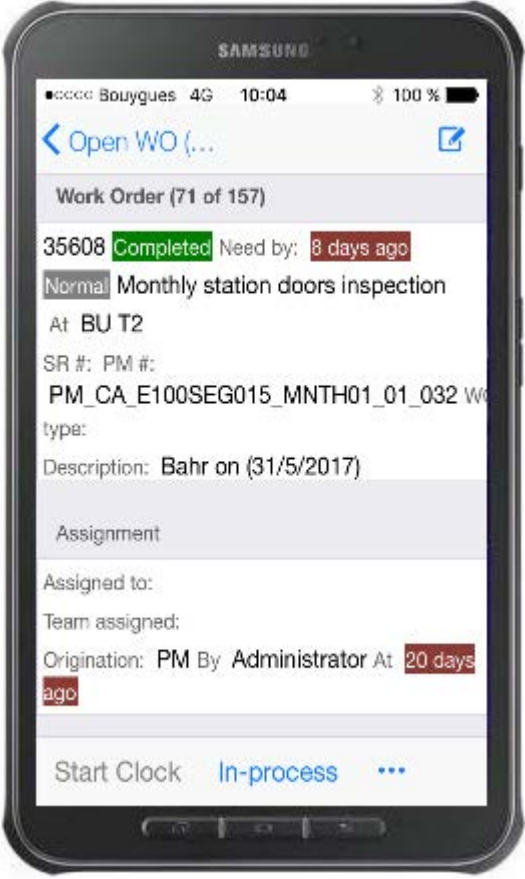

HyperView

EXPLOITATION
DIRECT LIVE
DISPONIBILITE
FREQUENTATION
ENERGIE
EXPORT
MURALEUR
FONCTION
PARAMETRES
APPAREILS
FAUCHE Michael Administrateur

TOUS LES APPAREILS

CETTE PAGE VA SE REACTUALISER DANS 6 SECONDES

Appareil	Marche Arrêt	Vitesse cible en m/s	Vitesse cible en %	Couple minia	Taux d'occupation	Nombre de passages	Débit	Vitesse vent	Nombre d'arrêts	Temps d'arrêt
IC Bab El Qued - En Construction	●	0 m/s	0%	0%	0%	0	0 p/h	0 m/s	1	12:00:00
TPH FI Madonie	●	0 m/s	0%	0%	0%	672	336 p/h	1.8 m/s	0	00:00:00
TPH Haute Drome d'Albique - En cours de rénovation	●	0 m/s	0%	0%	0%	0	0 p/h	0 m/s	0	00:00:00
IC Blide 11	●	4.1 m/s	81%	24.8%	0%	10	0 p/h	1.5 m/s	3	00:50:59
IC Blide 12	●	4 m/s	80%	16.5%	0%	0	0 p/h	5.5 m/s	7	00:09:40
TPH Memorial	●	0 m/s	0%	0%	0%	160	240 p/h	0.9 m/s	0	00:00:00
TPH Palais de la Culture	●	0 m/s	0%	0%	0%	70	60 p/h	1.8 m/s	0	00:00:00

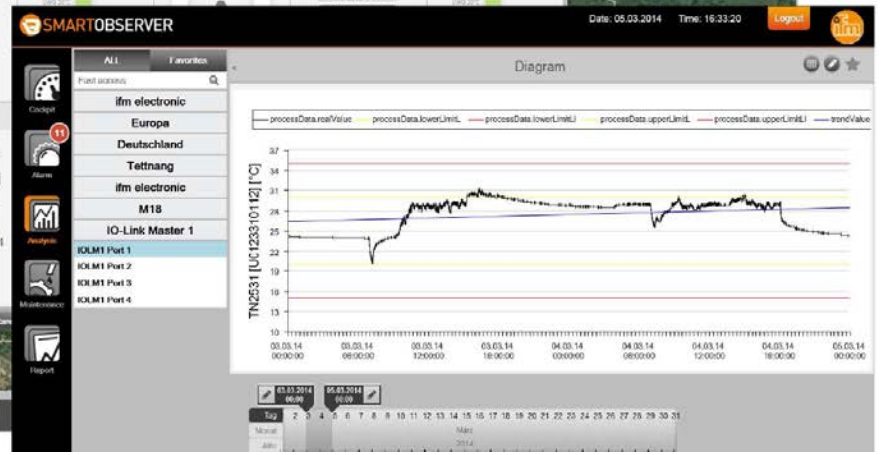
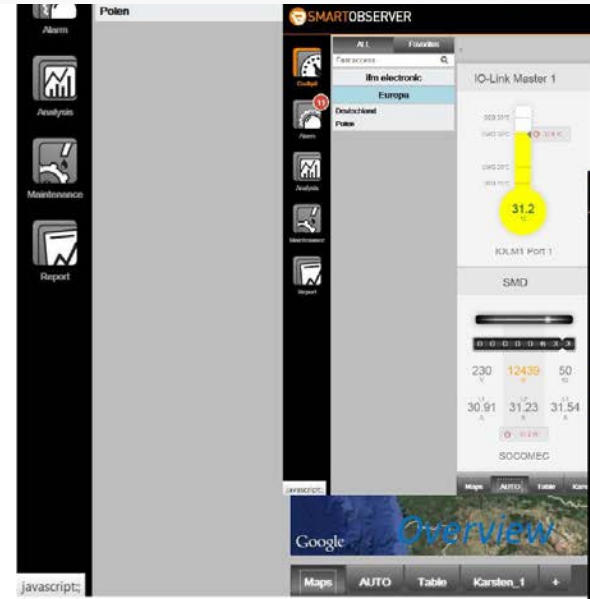
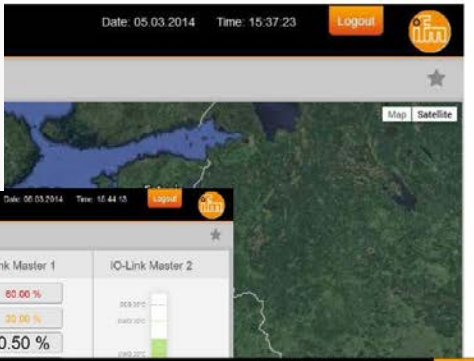



POMA

**THANK YOU
FOR YOUR
ATTENTION**

michael.fauche@poma.net