



Hauling rope package

The long term rope properties depend by:

- **Rope construction selection**
- **Proper fiber core support**
- **Low stretch**
- **Reliable splice**

All these tasks must be carefully considered during design, manufacture and installation of each wire rope.

Hauling rope interfaces

The load is supported by the line rollers.

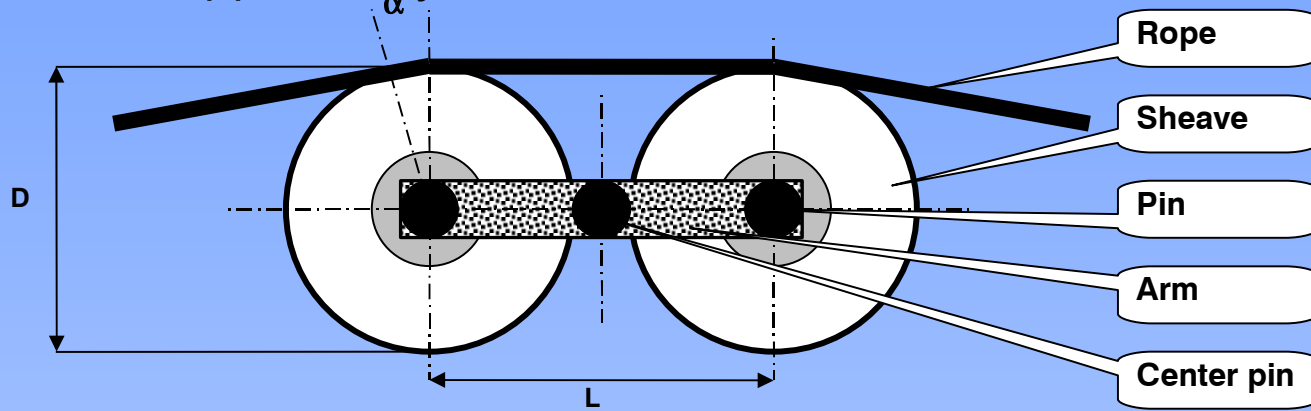

Each tower may contains several roller pairs.

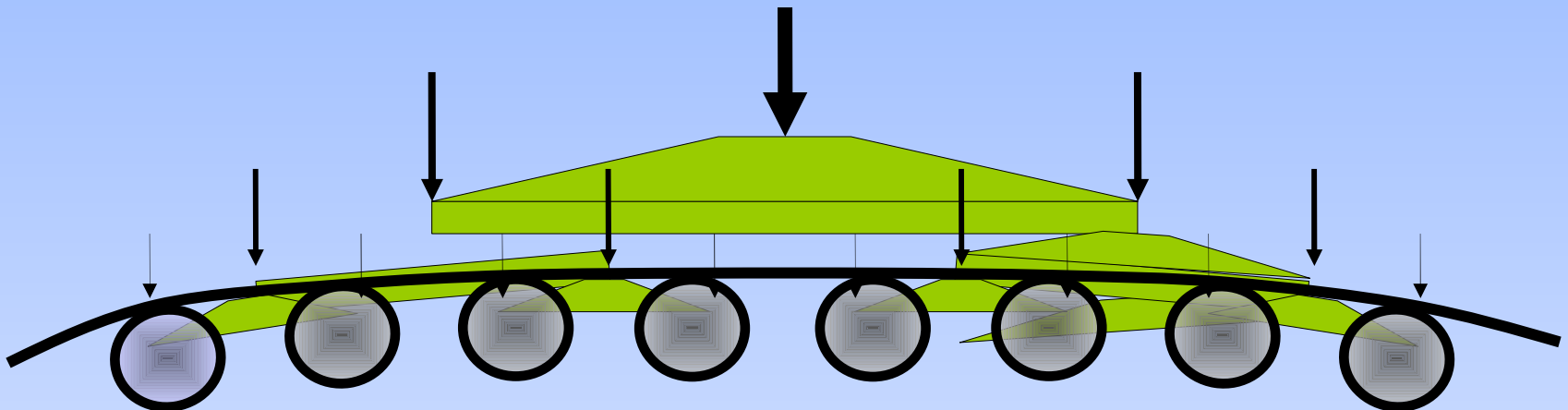

Hauling rope interfaces

The better roundness of 7 strand rope reduce the amplitude of the roller movements.

This will improve the passenger comfort.

This will also reduce the occurrence of breakages of the installation structures due to high frequency fatigue.

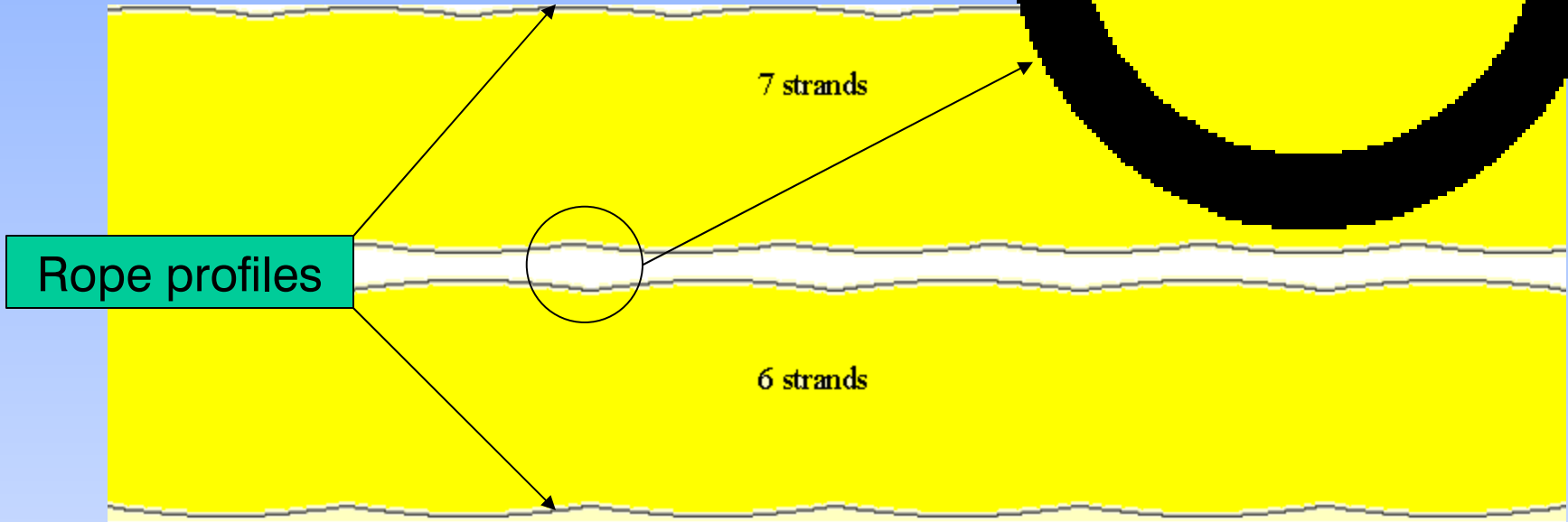
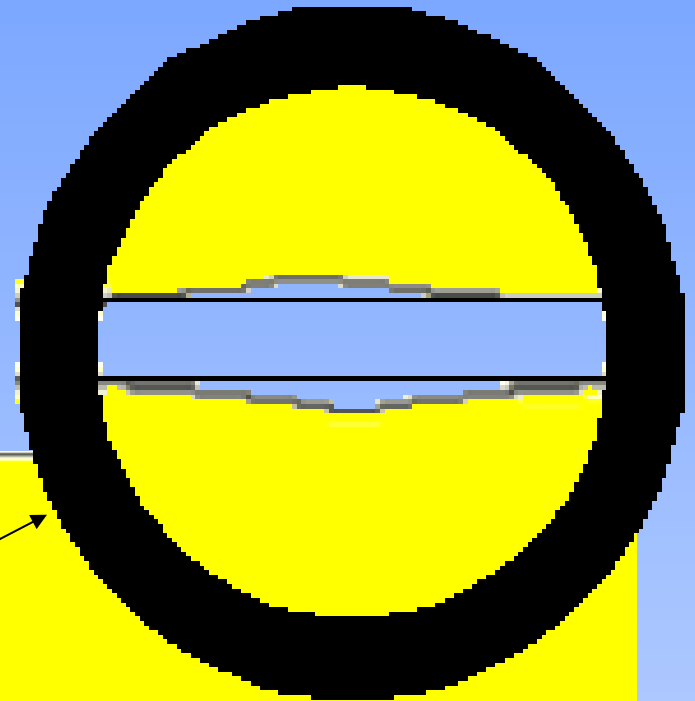

Hauling rope interfaces

The ropes roundness can be compared by their profiles.

The scheme below is a magnified plot of the profiles of ropes with 6, 7, and 8 strands.

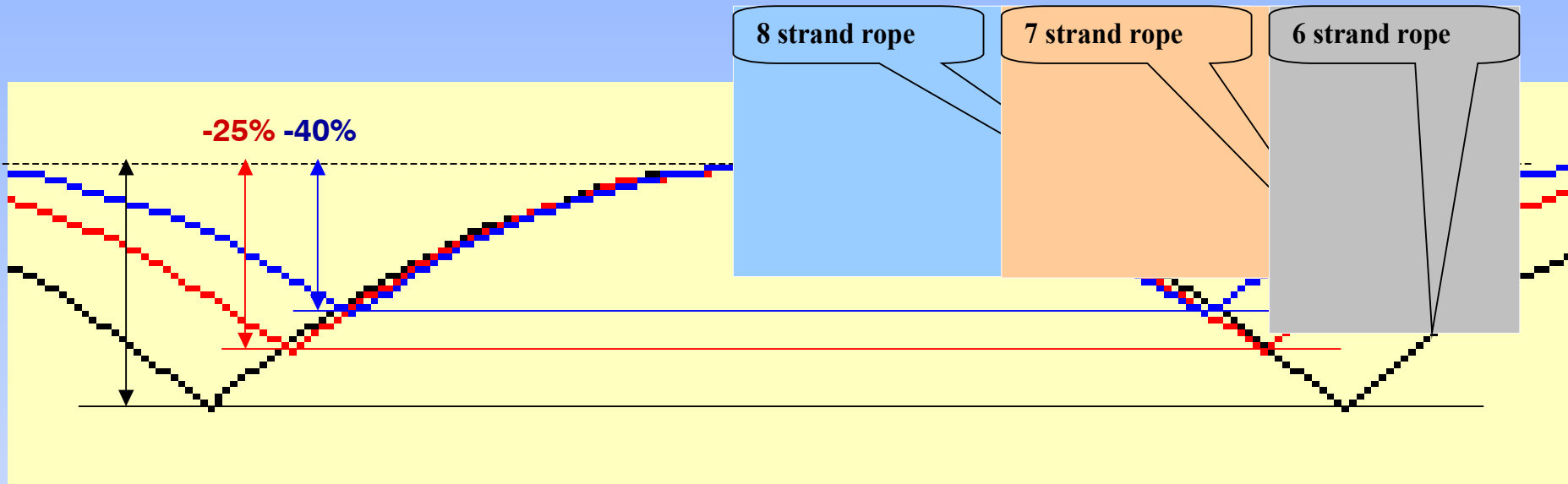

Hauling rope interfaces

The particular construction of the rope extend the contact points with the sheaves therefore this rope will improve the rollers' lining lifetime

Since flexibility depends mainly by the number of strands, this rope will also allow to adopt smaller rollers in respect to other 6 strand ropes.

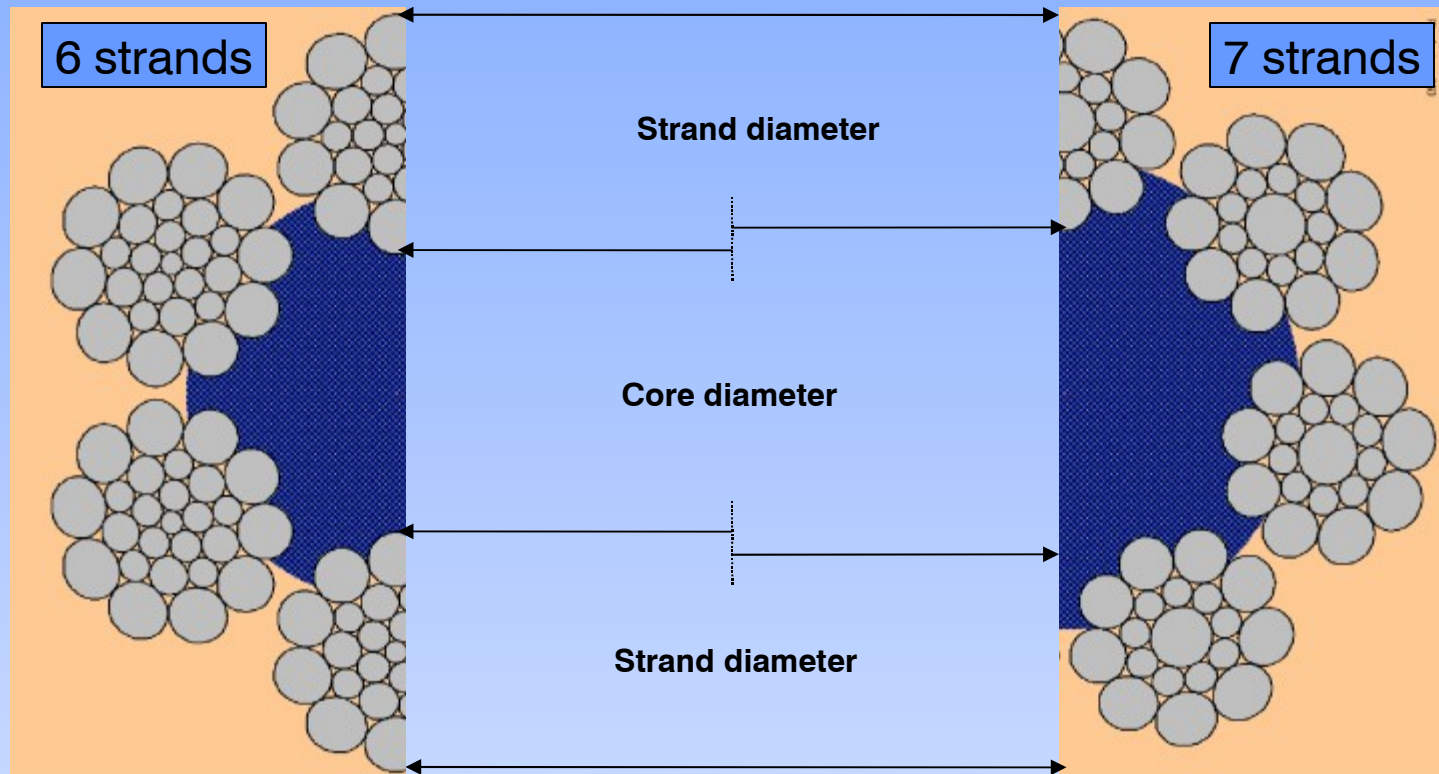

Hauling rope interfaces

The smaller strands allow to adopt strand constructions made with a few number of wires .

This improves the stability of the rope against the clamping pressure and improve the splice reliability.

The rope deformation at the tucks will be much less in respect to 6 strand ropes

Hauling rope design criteria

General rules

All the ropes for hauling-carrying operation must have a fiber core in order to allow splices. Therefore the ropes must be produced with a single layer of strands over a core.

The number of strands must be not less than 6 to allow the splice (with a lower number of strands, the core diameter would be smaller than those of the outer strand).

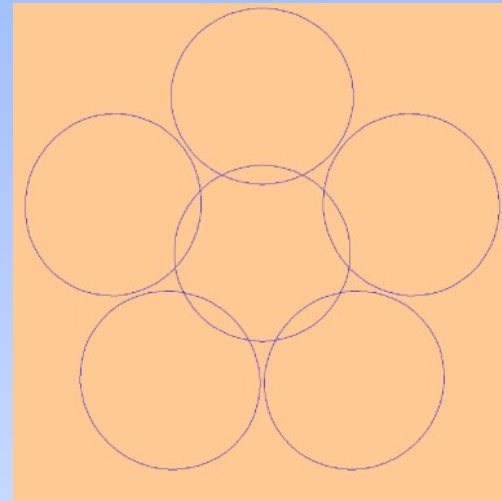
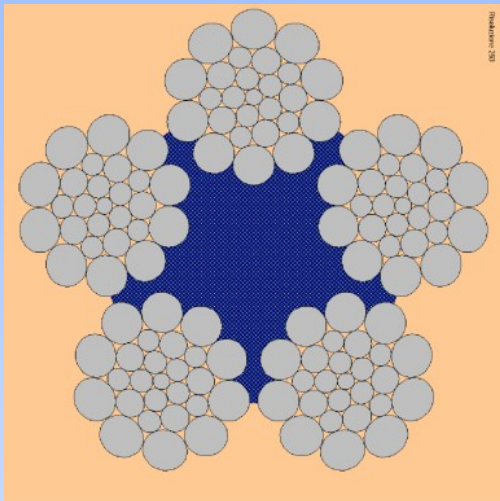

Hauling rope design criteria

Characteristic	Goal	Obtained by
High metallic area	To increase load capacity	6 outer strands
Roundness	To prevent vibrations	increased number of outer strands
Extended surface	To reduce the pressure over the rollers and sheaves	increased number of outer strands
Flexibility	To increase the contact surface with the grips To reduce bending stresses	increased number of outer strands
Large outer area	To reduce the rope wear	increased number of outer strands
Suitability for splicing	To prevent knots oversize	increased number of outer strands
Low stretch	To prevent excessive shortening operations	6 outer strands

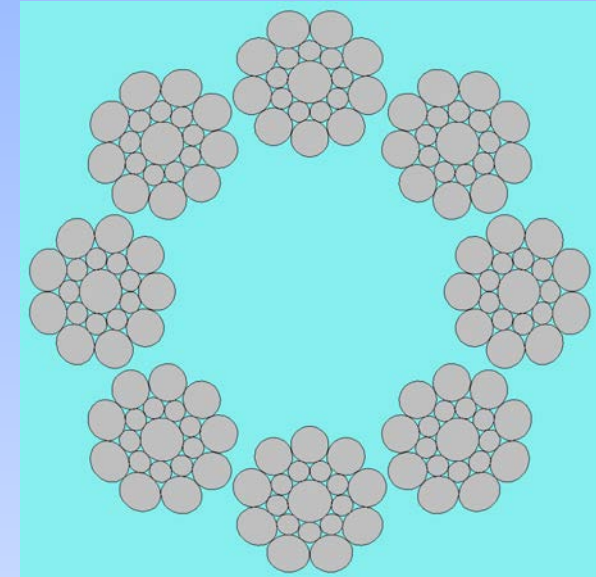
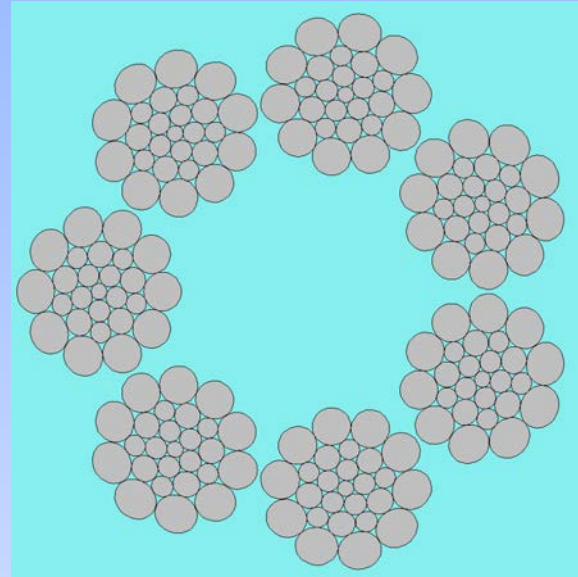
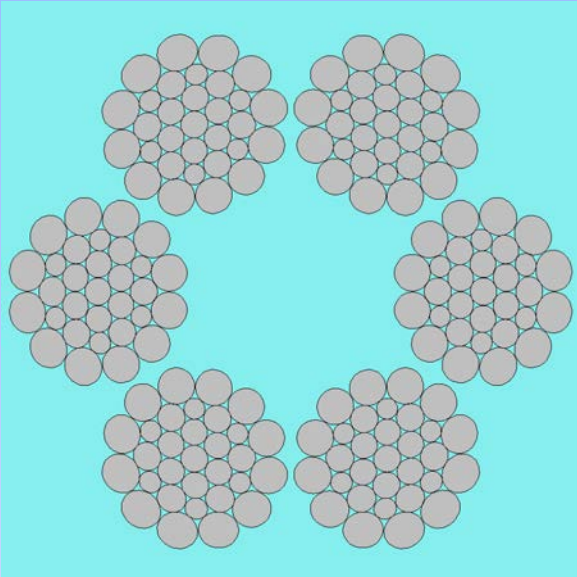

Hauling rope design criteria

The rope metallic area decreases with the number of strands.

The adoption of compacted strands, for 7 and 8 strand ropes, can compensate their reduction of area.

The graph represents the rope fill factor depending by the combination of various rope and strand types.

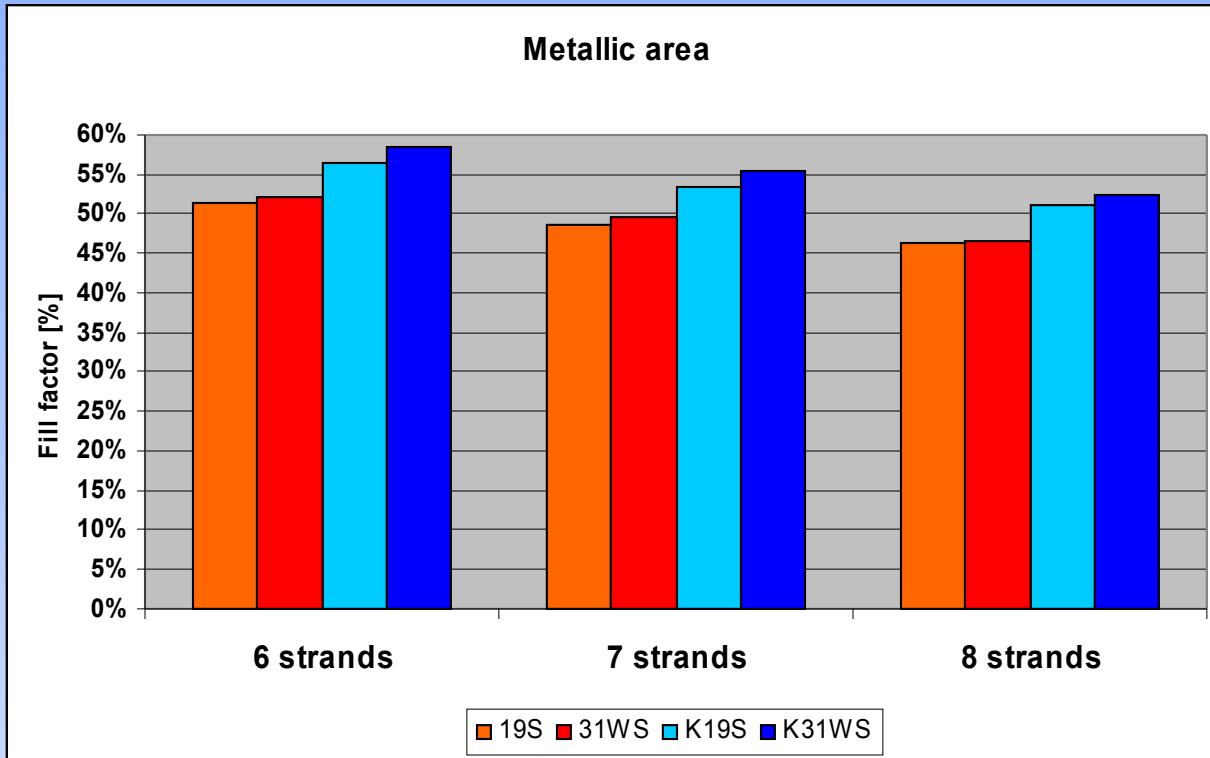

Fibre core dimensioning

The core is the key to obtain a stable and long lasting rope.

The materials to be used for the core must be non sensitive to environmental conditions (low and high temperature, UV rays deterioration, water absorption, aging etc.).

The core must be designed taking into account that the air trapped between the fibers must be eliminated during the rope closing by the combined action of pressure (generated by the outer strands) and time (depending by the closing speed).

For this purpose it is crucial to know the amount of the core volume which can be contained in the rope, and to produce a core having a structure that is easy to modify, in order to assume the shape that the core will take due to the outer strands.

Fibre core dimensioning

Step 1

To determine the strand dimensions when they will be in contact.

This corresponds at the “end of the life” condition.

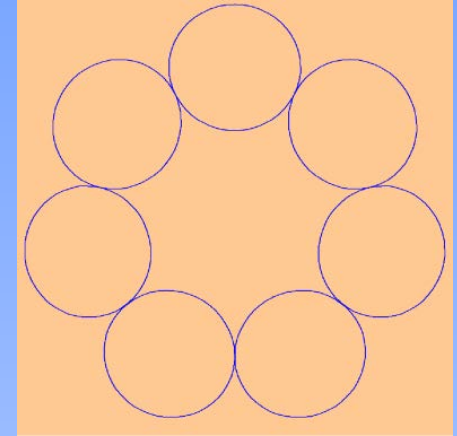

Step 2

To determine the exact rope cross section

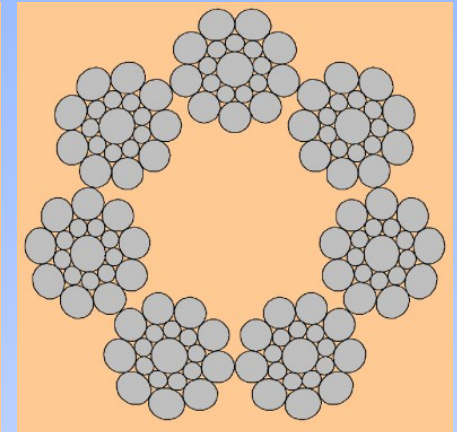
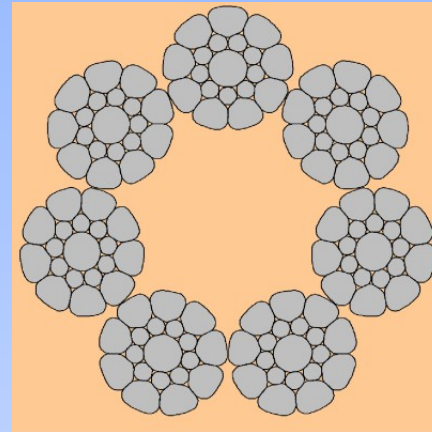

Fibre core dimensioning

Step 3

To determine the exact volume of the fibre core which can be included in the rope.

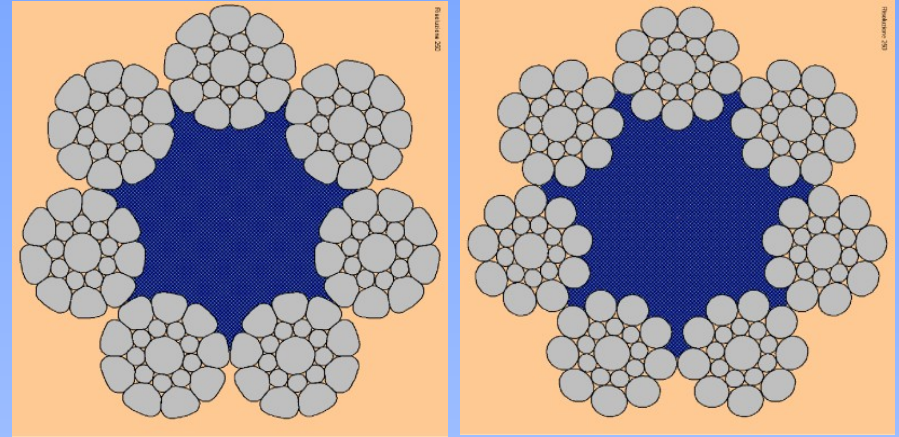

Step 4

To determine the expected rope dimensions during manufacture, installation and plant set-up.

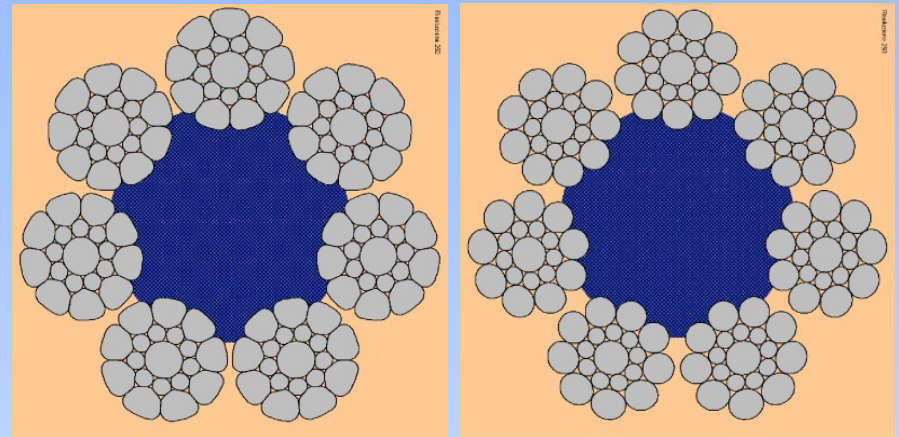

Fibre core dimensioning

The fibre core



The closing process

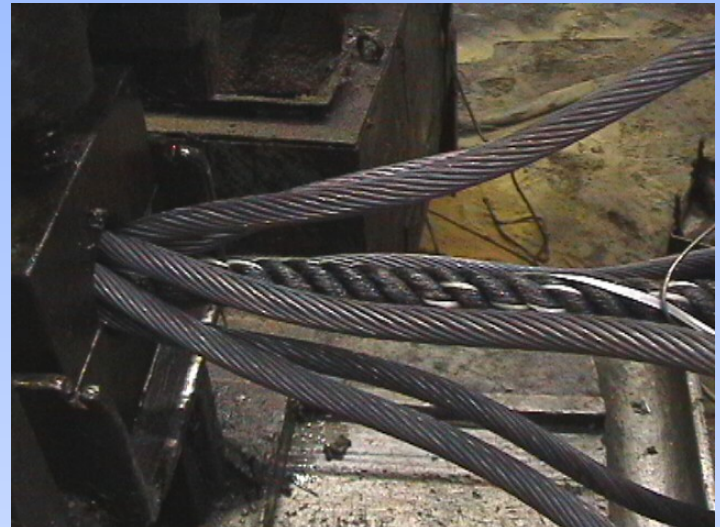

Rope dynamic prestretching

The scope is to reduce the elongation of the rope when loaded.

Knowing that the splice area is the most critical part of the rope, the absolute value of the rope elongation should be selected to allow one additional rope splice (The tucks of a rope with no elongation at all, can not be relocated).

This process consists of loading and bending the rope during its manufacture over a double traction winch (the first half of the machine increases the load to the rope, the second half lowers the load).

The tension applied at the rope can be adjusted, using a hydraulic driven sheave, up to 80 tons.

The pre-stretching machine, which is about 90 m long, increases the time during which the rope is under tension, improving the effect of the pre-stretching.

Rope dynamic prestretching

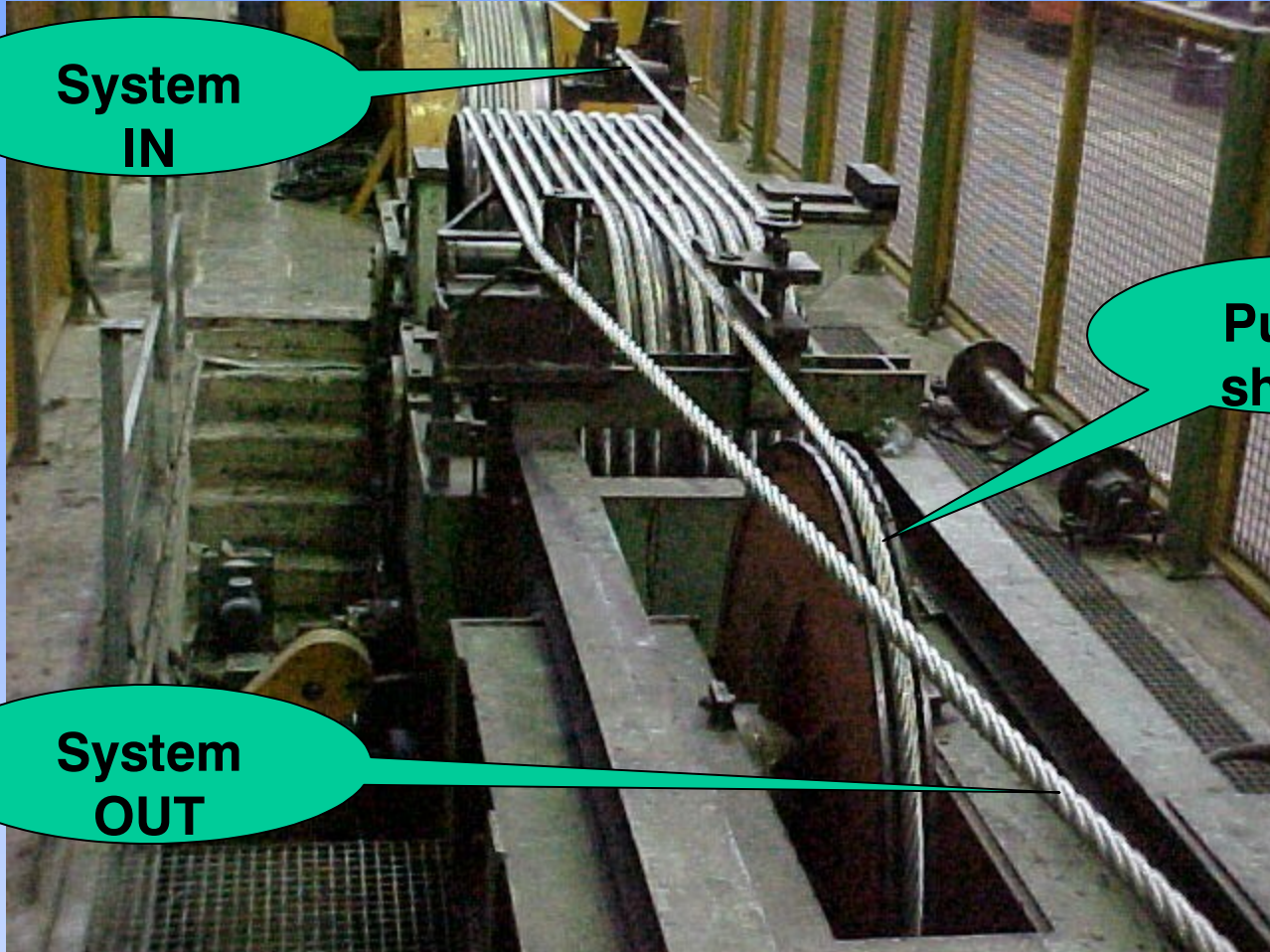

**System
IN**

**Pulling
sheave**

**System
OUT**

Rope prestretching

Wire rope stretch
Hauling and carrying ropes with detachable grips

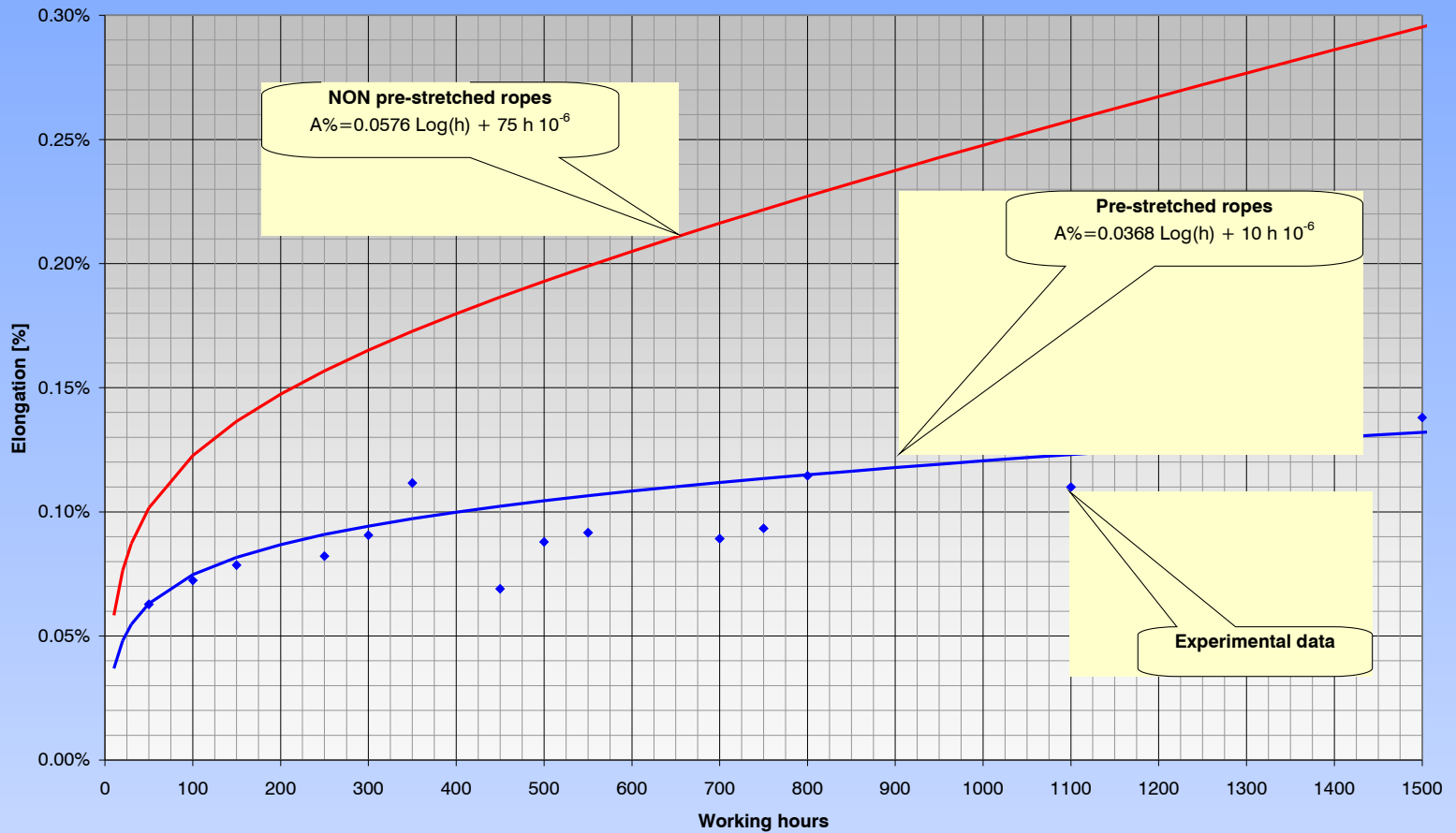

Tail wrapping material

To maintain the requested stability of the splice, the tails must be wrapped in order to be “forced” inside the outer strands in place of the fiber core.

The material to be used for the tail wrapping must be wound in the exact quantity to ensure the longest working time and to keep the geometrical dimensions of wire rope constant.

For this purpose the most modern method of wrapping uses reinforced rubber hose cut longitudinally and wound over the tail. This choice of material allows to find a wide variety of dimensions and types on the market, to operate with any kind of rope and size.

The scheme represents the longitudinal and the cross sections of the splice area of a 7 strand rope.

Tail wrapping material

Splice longitudinal section

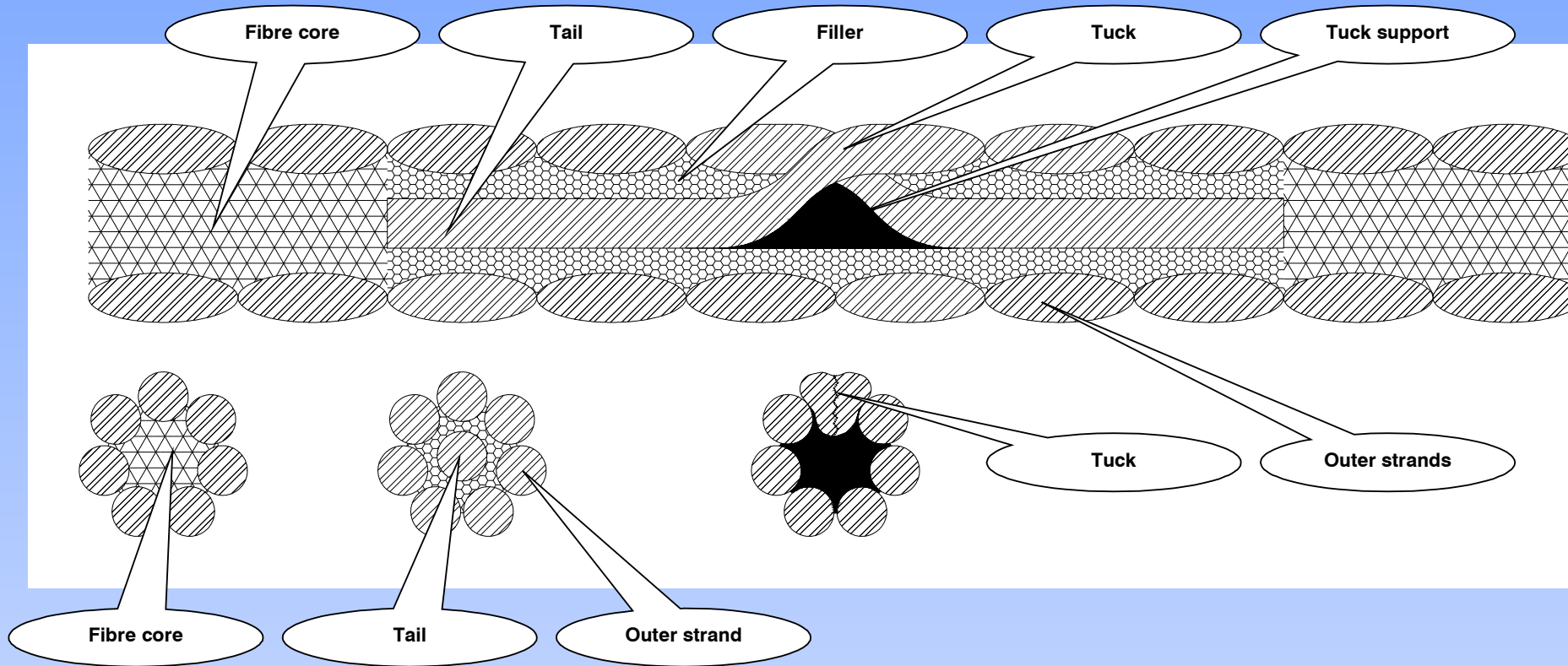

Tail wrapping material

Splicing in progress



Tail wrapping material

The final result

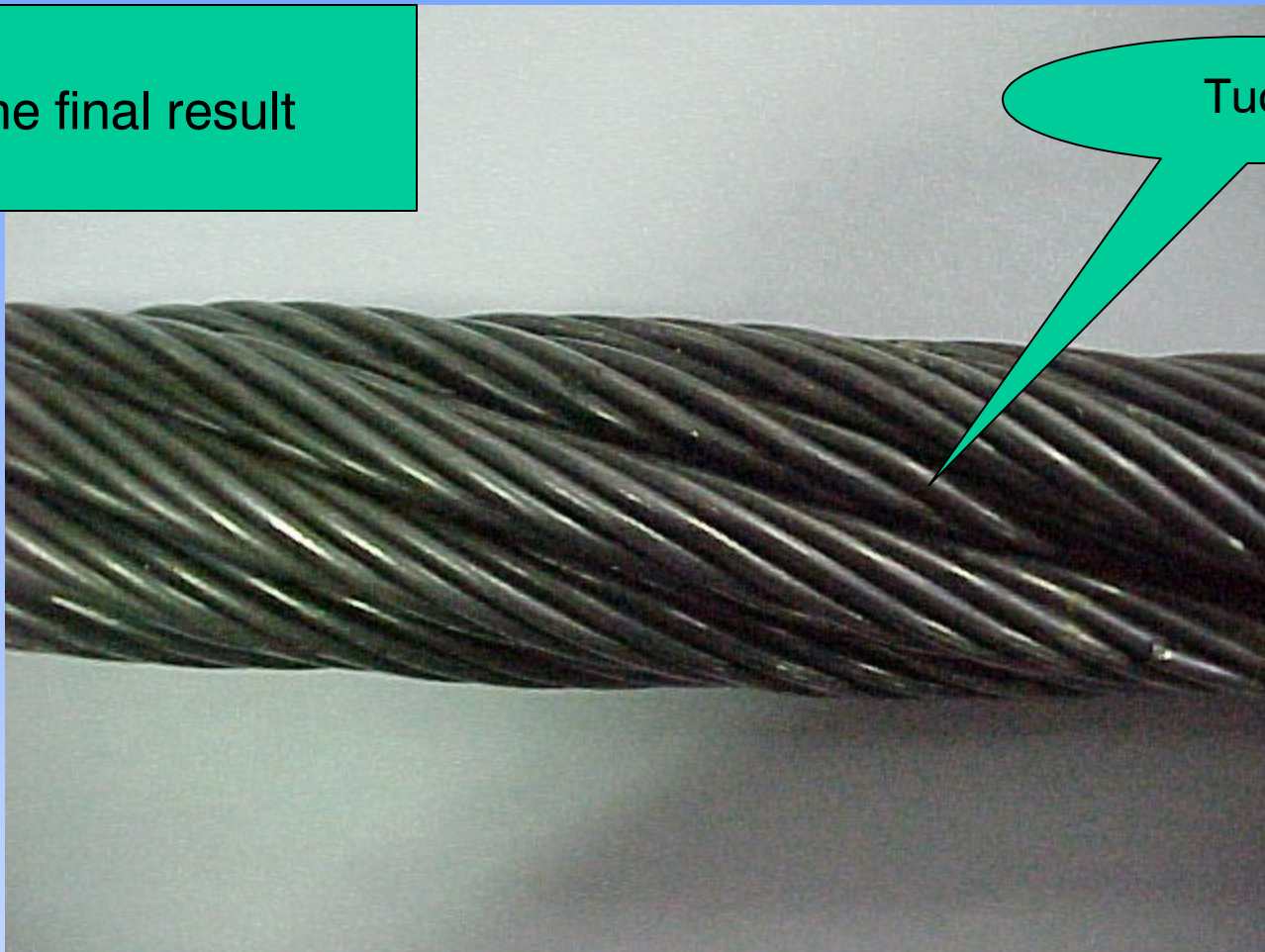

Tuck

Experimental results

The practical results of the installation of 7 strands rope confirm the suitability of the rope for the scope of reducing vibrations and noise.

A	Chairlift	34 mm x 1400 m – bright –	2002 – replacement of the old rope
B	Chairlift	36 mm x 2150 m – galvanized –	2002 – first equipment
C	Cableway	32 mm x 1740 m – bright –	2002 – replacement of the old rope
D	Cableway	34 mm x 1740 m – bright –	2002 – replacement of the old rope
E	Chairlift	30 mm x 2050 m – bright –	2002 – replacement of the old rope
F	Funicular	33 mm x 1600 m – bright –	2002 – replacement of the old rope
G	Cableway	32 mm x 1850 m – bright –	2003 – replacement of the old rope
H	Cableway	35 mm x 1670 m – bright	2004 – Plant revamping
I	Cableway	35 mm x 3340 m – bright	2004 – Plant revamping
J	Cableway	25 mm x 3200 m – galvanized	2004 – replacement of the old rope
K	Cableway	25 mm x 2480 m – galvanized	2004 – replacement of the old rope
L	Chairlift	42 mm x 2805 m – galvanized	2004 – first equipment
M	Cableway	27 mm x 2300 m – bright	2004 – Plant revamping
N	Cableway	24 mm x 2300 m – bright	2004 – Plant revamping

Experimental results

ROLLER' VIBRATIONS

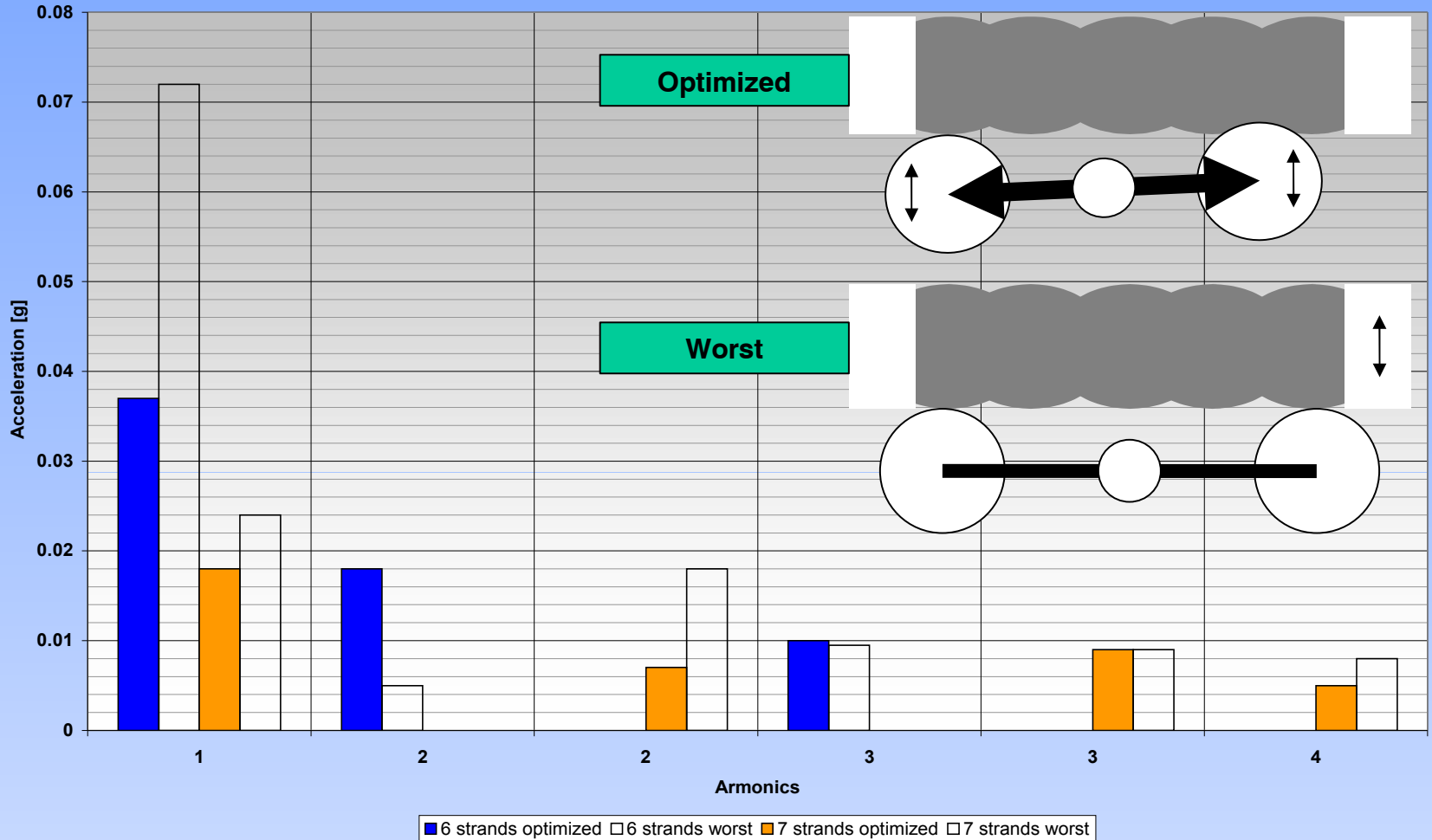

Conclusion

The new 7 strand rope, together with the cableway package, gives a number of advantages in comparison with the classic 6 strand rope:

- **Better pressure distribution over clamps, grips and rollers.**
- **Lower rollers' cost due to their possible reduction in size.**
- **Massive reduction of vibrations over the support structures.**
- **Controlled stretch**
- **Reliable and less invasive splice**

Most of 6 strand ropes can be replaced by the 7 or 8 strand ropes.